



STA

Centrifugal Liquid Recycling



AUTOMATIC WATER CLEANING SYSTEMS

TTS

CYCLONE TWIN TANK SYSTEM

- Particle accumulation enhancement
- No sludge deposits
- Space-saving design
- Clean water without chemicals

WITH **SELF-CLEANING** CENTRIFUGAL SEPARATOR A-25

- Outstanding Separation Performance (3µm)
- Unmatched flow capacity 170 lpm
- Dry sludge
- Easy operation with colour touch display
- Tungsten-carbide wear protection

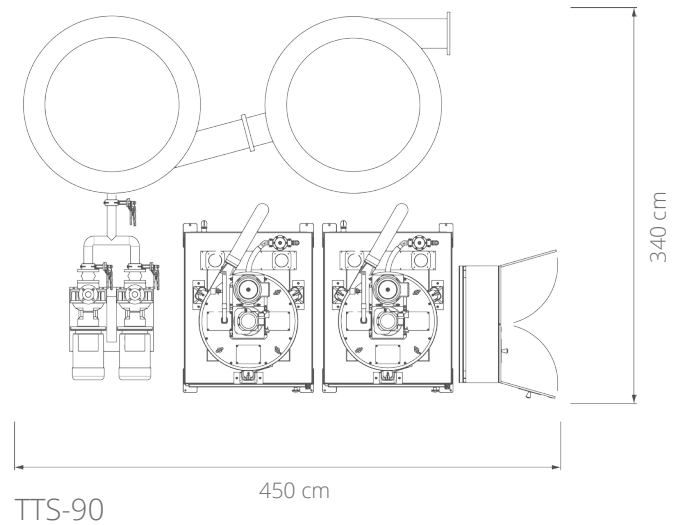
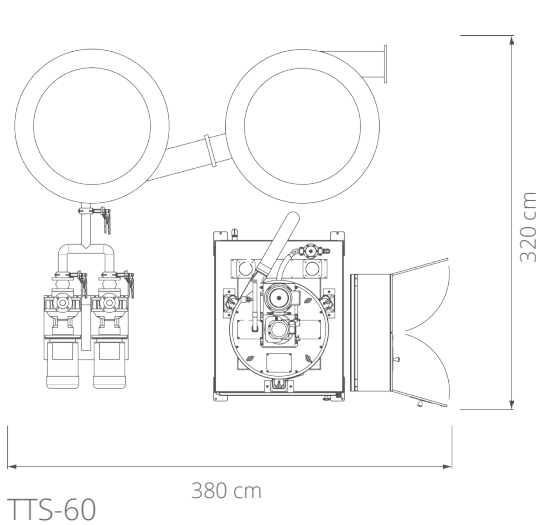

SPECIFICATIONS:

	TTS-60	TTS-90
Sludge capacity	40 kg/h	80 kg/h
Volume flow	60 m ³ /h	90 m ³ /h
Floor space (cm)	380 x 320	450 x 340

Separatoren-Technik & Anlagenbau GmbH
 Obere Giesswiesen 32
 D-78247 Hilzingen (Germany)

Telefon: +49 77 31 92 43 0
 Telefax: +49 77 31 92 43 11

www.sta-separator.de
info@sta-separator.de

